

Specifications

Remark : () Option

Item	Unit	LA-350M
Capacity		
Max. swing	mm	780
Std. turning diameter	mm	300
Max. turning diameter	mm	480
Max. turning length	mm	1481
Bar capacity	mm	115
Travel		
X axis travel	mm	275
Z axis travel	mm	1610
Spindle		
Gear change step		2 step
Spindle nose		A2-11
Chuck size		12"(15")
Spindle speed	rpm	2500(2000)
Through hole diameter	mm	126
Bearing diameter	mm	170
Turret		
Number of tools		T12
Turning tool shank	mm	32
Boring bar shank diameter	mm	50
Milling tool shank diameter	mm	26

Item	Unit	LA-350M
Tailstock		
Tailstock travel	mm	1610
Tailstock spindle diameter	mm	150
Taper hole of tailstock spindle		MT.5
Tailstock spindle travel	mm	150
Feedrate		
X axis rapid traverse rate	m/min	18
Z axis rapid traverse rate	m/min	20
Motor		
Spindle drive motor	kW	18.5/22(22/26)
Turret index motor	kW	1.2
Milling motor	kW	3.7/7.5
X axis drive motor	kW	4
Z axis drive motor	kW	4(7)
Size		
Height	mm	2150
Width	mm	6336
Depth	mm	2119
Weight	kg	9050

※ Specifications are subject to change without notice.

LA-350M

TAKISAWA
TAIWAN

LA-350M L16

CNC
LATHE

Tooling system

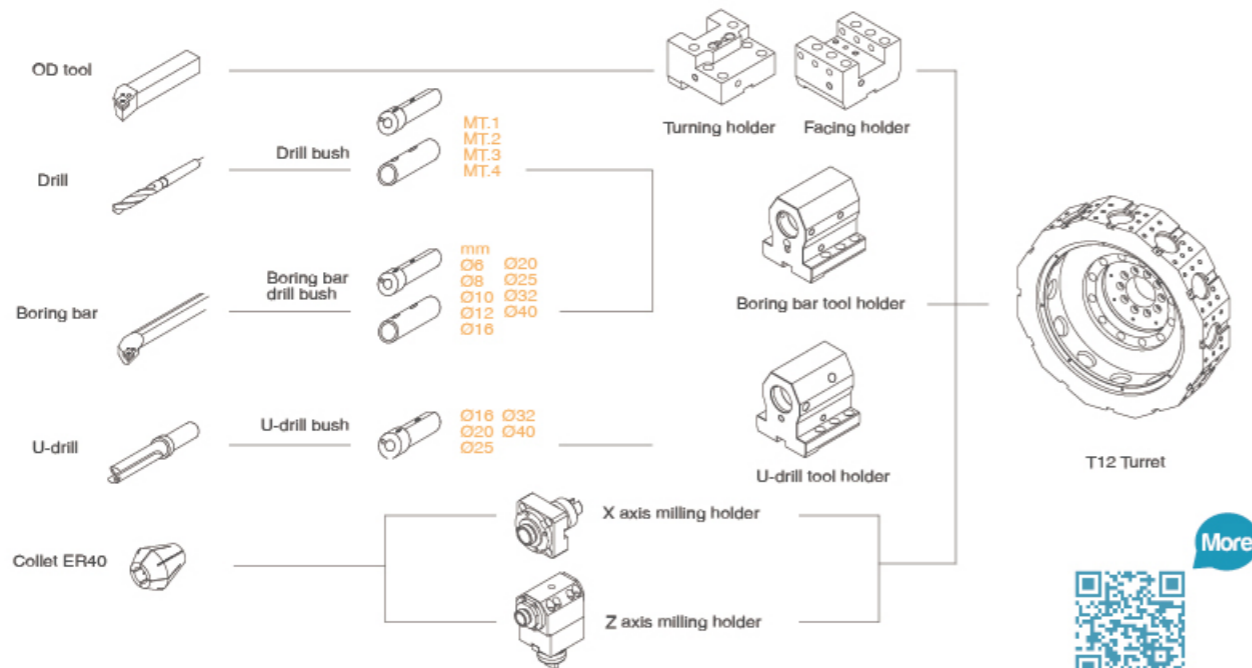

More



www.takisawa.com.tw



Taiwan TAKISAWA Technology Co., Ltd.

No.505, Sec. 3, Yenping Rd., Pingchen Dist., Taoyuan City 324, Taiwan.

TEL : +886-3-4643166 FAX : +886-3-4642614 E-mail : callcenter@takisawa.com.tw

Shanghai TAKISAWA Mechatronics Ltd.

No.1568, Yuanguo Road, Anting Town, Jiading District, Shanghai

TEL : +86-021-59562955 FAX : +86-21-59562956

TAKISAWA

TAIWAN

2017.08



Spindle output diagram

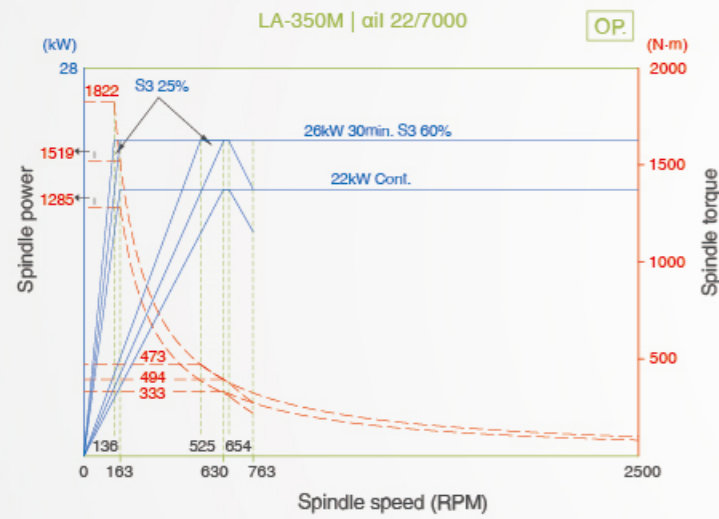
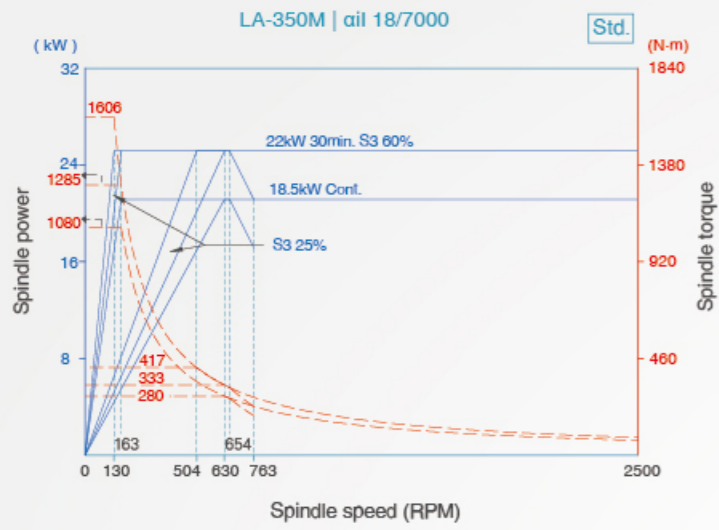

Power chart of milling tool

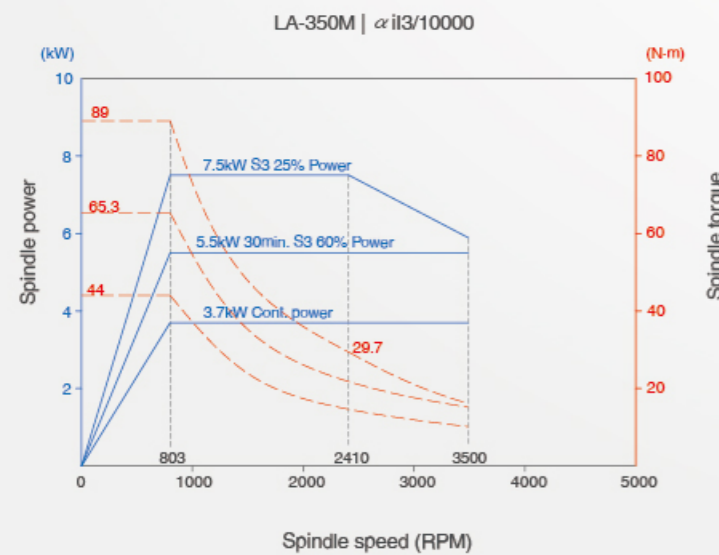

Working range

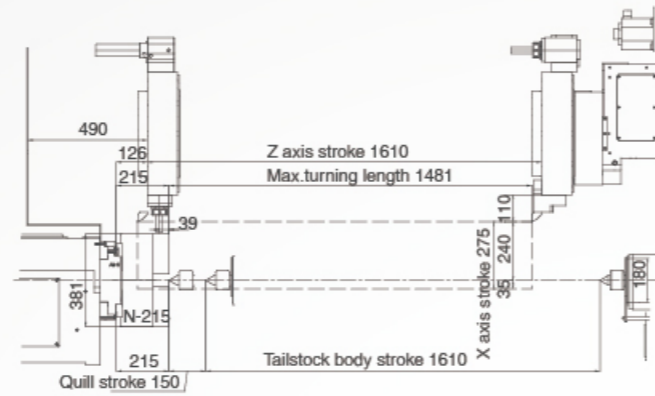

Interference diagram

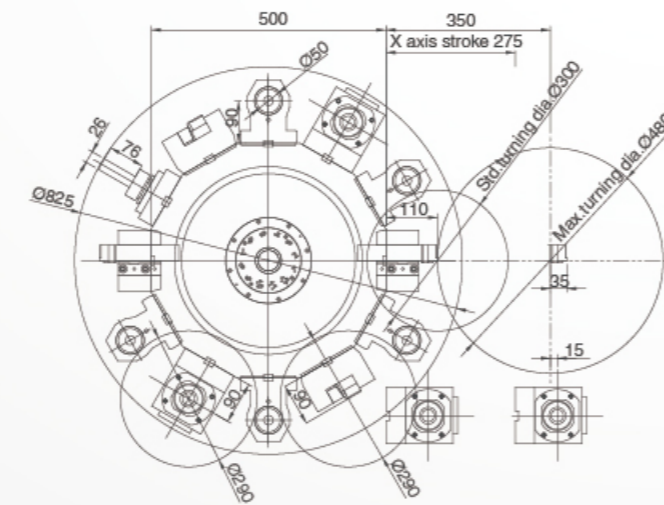

Machine dimensions

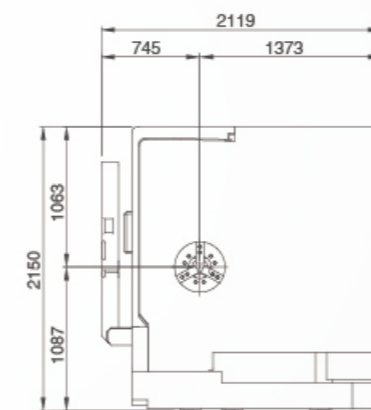
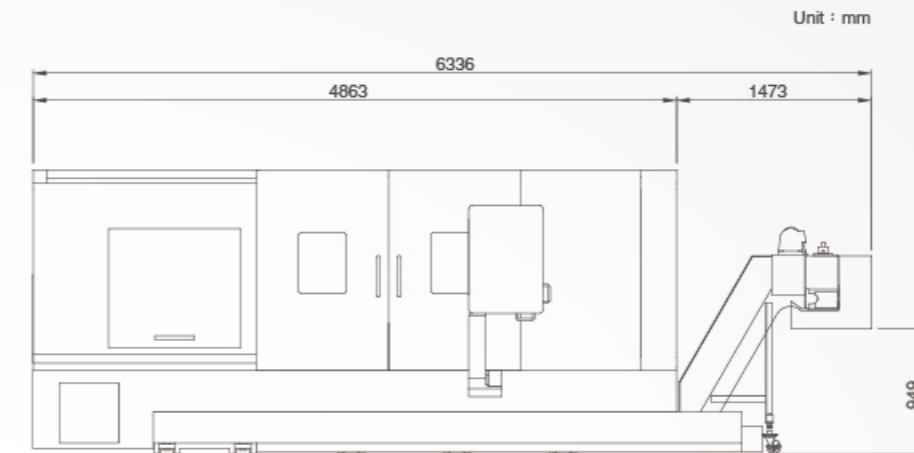

Box way design for all machining axes.

* Variations of coolant temperature influence the dimension of work-piece significantly. When heavy cutting is applied, the coolant cooler is highly recommended. However, it can not guarantee total control of temperature.

